

Aminocyclitols. XI. Studies on the Synthesis of *muco*-Inosadiazines and Inosatetraamine

Tetsuo SUAMI,* Frieder W. LICHTENTHALER** and Seiichiro OGAWA*

* Department of Applied Chemistry, Faculty of Engineering, Keio University, Koganei-shi, Tokyo

** Institut für Organische Chemie, Technische Hochschule, 61 Darmstadt, Germany

(Received November 22, 1966)

muco-Inositol was synthesized from 1, 4, 5, 6-tetra-*O*-acetyl-3-*O*-sulfonyl-*myo*-inositol in a fairly good yield by a new synthetic route. When sulfonyloxy groups were replaced by azide ion in *muco*-inositol derivatives, *muco*-inosadiazine-3, 6, *myo*-4, 6 and *muco*-inosatetraamine-1, 2, 4, 5 were obtained. Their structures were established by means of proton magnetic resonance spectroscopy. By an analogous reaction, 2, 4, 5, 6-tetra-*O*-acetyl-1, 3-di-*O*-*p*-toluenesulfonyl-*myo*-inositol gave *muco*-inosadiazine-1, 4.

In previous papers of this series, it has been described that the replacement of the methanesulfonyloxy group by an azide ion takes place through an intermediary acetoxonium ion, with the participation of the vicinal acetoxy group in the trans orientation.¹⁾ In the present studies new inosadiazines have been prepared using *muco*-inositol as a starting material, and the configurations of the products obtained have been established by means of proton magnetic resonance (PMR) spectroscopy.

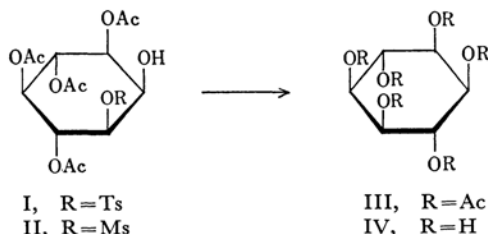

***muco*-Inositol.** *muco*-Inositol (IV) had been prepared by several authors.²⁻⁶⁾

However, in the present experiment *muco*-inositol was synthesized from *myo*-inositol in a fairly good yield by the following new synthetic route. 1, 4, 5, 6-Tetra-*O*-acetyl-3-*O*-*p*-toluenesulfonyl-*myo*-inositol (I)⁷⁾ or 1, 4, 5, 6-tetra-*O*-acetyl-3-*O*-

methanesulfonyl-*myo*-inositol (II)⁸⁾ was successfully used for the preparation of IV. When I or II was treated with sodium acetate in boiling 90% aqueous 2-methoxyethanol for 15 hr, the sulfonyloxy group was displaced by an acetate ion, the subsequent rearrangement giving *muco*-inositol hexaacetate (III) in 74% or 64% yield respectively, after acetylation.

The PMR spectrum of III in deuteriochloroform shows two sharp signals due to the acetoxy group, at τ 7.92 (6H) and 7.95 (12H). This fact was explained by Brownstein⁹⁾ in terms of the rapid inversion between the alternative identical chair forms of the cyclohexane ring. Even if the inversion is rapid, however, it still does not average the chemical shifts of all the acetoxy groups, they still give the two peaks in the spectrum.

The stereochemical course of this reaction might be explained as follows: the displacement of the sulfonyloxy group in I or II takes place through the anchimeric intermediate acetoxonium ion, with the participation of the neighboring acetoxy group¹⁰⁾ and its trans-diaxial opening by an acetate ion.

***muco*-Inosadiazine-3, 6 and *myo*-Inosadiazine-4, 6.** The compound IV was treated in acetone under reflux in the presence of anhydrous zinc chloride to yield 1, 2, : 4, 5-di-*O*-isopropylidene-*muco*-inositol (V).¹¹⁾ V was treated with methanesulfonyl chloride to give 1, 2, : 4, 5-di-*O*-isopropylidene-3, 6-di-*O*-methanesulfonyl-*muco*-inositol (VI) in a 95% yield. VI was hydrolyzed by 90%

1) T. Suami, F. W. Lichtenthaler and S. Ogawa, This Bulletin, **38**, 754 (1965); **39**, 170 (1966).

2) G. Dangschat and H. O. L. Fischer, *Naturwissenschaften*, **27**, 756 (1939).

3) M. Pitman (with S. J. Angyal), M. Sc. Thesis, University of New South Wales, Sydney, 1957.

4) S. J. Angyal and C. Curtin, unpublished work; S. J. Angyal and L. Anderson, "Advances in Carbohydrate Chemistry," Vol. 14, Academic Press, New York (1959), p. 167.

5) M. Nakajima, I. Tomida, N. Kurihara and S. Takei, *Chem. Ber.*, **92**, 173 (1959).

6) S. J. Angyal, V. Bender and J. H. Curtin, *J. Chem. Soc.*, **1966**, 798.

7) S. J. Angyal, P. T. Gilham and G. J. H. Melrose, *ibid.*, **1965**, 5252.

8) T. Suami and S. Ogawa, This Bulletin, **37**, 1238 (1964).

9) S. Brownstein, *Can. J. Chem.*, **40**, 870 (1962).

10) E. S. Gould, "Mechanism and Structure in Organic Chemistry," Rinehart and Winston, New York (1956), pp. 565—566.

11) S. J. Angyal and R. M. Hoskinson, *J. Chem. Soc.*, **1962**, 2985.

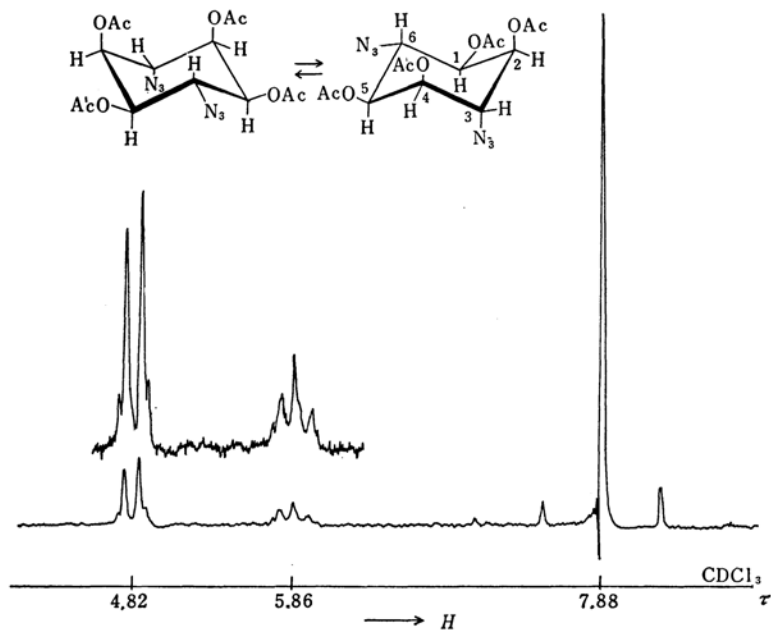
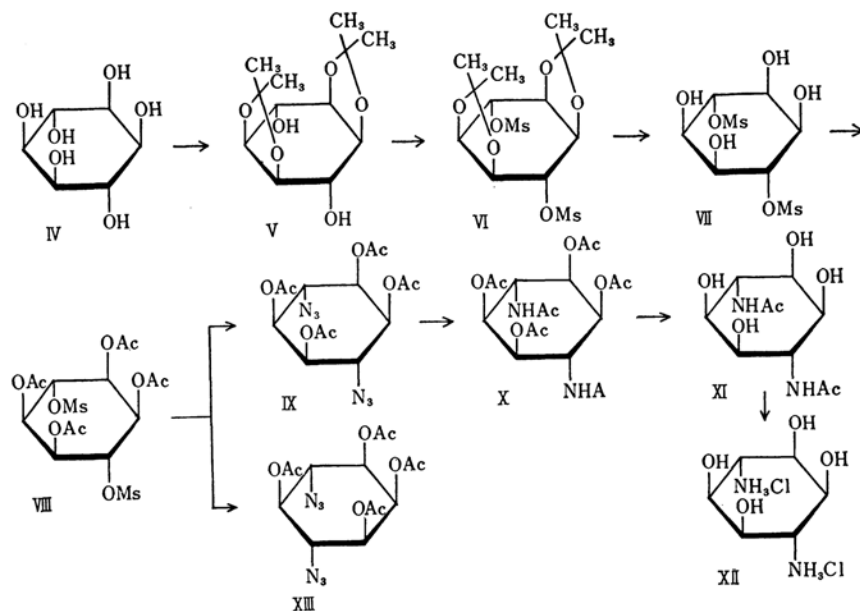

Fig. 1

aqueous acetic acid to afford 3,6-di-*O*-methanesulfonyl-*muco*-inositol (VII). Then VII was acetylated to yield 1,2,4,5-tetra-*O*-acetyl-3,6-di-*O*-methanesulfonyl-*muco*-inositol (VIII) in a quantitative yield. When VIII was treated with sodium azide in boiling aqueous 2-methoxyethanol for 46 hr, a mixture of two diazido compounds, IX and XIII, was obtained. Fractional recrystallizations of the mixture separated IX and XIII effectively in crystalline states, in 76.0 and 3.6% yield respectively.

The compound XIII was identified, by a mixed-melting-point determination with an authentic sample and by a comparison of their infrared spectra, as 1,2,3,5-tetra-*O*-acetyl-4,6-diazido-4,6-dideoxy-*myo*-inositol.¹²⁾

On the other hand, the compound IX was hydrogenated, and the reduction product was acetylated by the usual procedure to give hexaacetyl-

12) T. Suami and S. Ogawa, This Bulletin, **38**, 2026 (1965).

muco-inosadamine-3, 6 (X) in 78% yield. A selective hydrolysis of *O*-acetyl groups of X gave di-*N*-acetyl-*muco*-inosadamine-3, 6 (XI) in 90% yield. *muco*-inosadamine-3, 6 dihydrochloride (XII) was prepared by the acid hydrolysis of the crude reduction product.

The configurational proofs of *muco*-inosadamine derivatives were obtained by a study of the PMR spectra.

The spectrum of VIII in deuteriochloroform shows two methanesulfonyloxy groups and the four acetoxy groups. If this compound would have a fixed chair conformation, four signals might be expected, because there are one equatorial and one axial methanesulfonyloxy group, and two equatorial and two axial acetoxy groups. However, the observed spectrum shows only two sharp signals instead of four. This fact could be explained in terms of the rapid inversion between two alternative identical chair conformations.

Also, the spectrum of the diazido derivative, IX, in deuteriochloroform (Fig. 1), exhibits only one sharp signal, at τ 7.88 (12H), arising from the four acetoxy groups. The protons on the cyclohexane ring give a doublet at τ 4.82 (4H) and a triplet at τ 5.86 (2H). The observed spin-spin coupling constant obtained by the first-order analysis is 6.0 cps in both signals. This value is not far from the average coupling constant of 5.5 cps between axial-axial and equatorial-equatorial or equatorial-axial protons.¹³⁾ The signal at τ 4.82 corresponds to the protons on C-1, 2, 4 and 5. While the protons on C-3 and 6 appear as a triplet at τ 5.86, which shows that they are equivalent and are coupled to the protons on the neighboring carbon atoms. More informations on the conformation of IX can be obtained from its low-temperature PMR spectrum.¹⁴⁾ When the probe

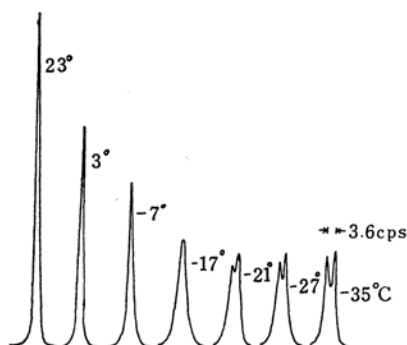

Fig. 2a. PMR spectra of acetoxy protons of IX in CDCl_3 .

13) G. E. McCasland, S. Furuta, L. F. Johnson and J. N. Shoolery, *J. Org. Chem.*, **29**, 2354 (1964); G. E. McCasland, "Advances in Carbohydrate Chemistry," Vol. 20, Academic Press, New York (1965), p. 56.

14) E. L. Eliel, N. L. Allinger, S. J. Angyal and G. A. Morrison, "Conformational Analysis," Interscience, New York (1965), p. 153.

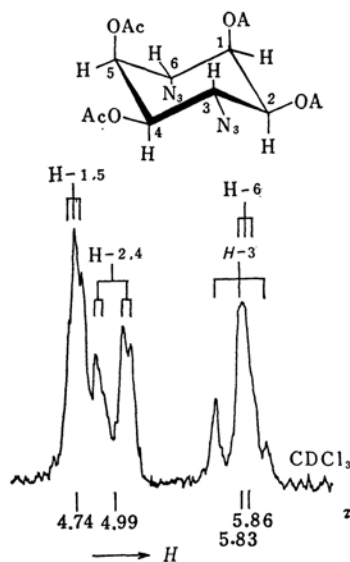

Fig. 2b. Partial PMR spectrum of ring protons of IX at -27°C .

$$J_{aa} = 9.5 \text{ cps} \quad J_{ae} = J_{ee} = 2.6 \text{ cps}$$

temperature was lowered, the peaks of the four acetoxy groups were successively broadened, finally each separating into two peaks with the same intensity (Fig. 2a). The peak at the higher field was assigned to the equatorial acetoxy groups, and the peak at the lower field, to the axial groups. The ring proton signals in the spectrum at -27°C appear as clearly-separated peaks, as is shown in Fig. 2b. These facts also support the rapid inversion of two superimposed chair conformations.

The spectrum of X in deuteriochloroform shows only one sharp signal, at τ 7.92 (12H), for the four acetoxy groups, and one sharp signal, at τ 8.03, (6H) for two acetamido groups. The NH protons appear as a doublet at τ 2.42 (2H) ($J=9.0$ cps).¹⁵⁾

TABLE I. CHEMICAL SHIFTS (τ) OF *MUCO*-INOSITOL DERIVATIVES

Compound	Solvent	OAc	NHAc
III	CDCl_3	7.95(12)	—
		7.92(6)	—
VIII	d_6 -DMSO	7.89(12)	—
IX	CDCl_3	7.88(12)	—
X	CDCl_3	7.92(12)	8.03(6)
XI	D_2O	—	7.95(6)
XV	CDCl_3	7.87(12)	—
XVI	d_6 -DMSO	7.91(12)	8.10(6)
XVII	D_2O	—	7.95(6)
XIX	CDCl_3	7.86(6)	—
XXIII	d_6 -DMSO	7.91(6)	8.09(12)
XXIV	CDCl_3	—	—
	D_2O	—	7.98(12)

15) D. Horton and N. Turner, *J. Org. Chem.*, **30**, 3392 (1965).

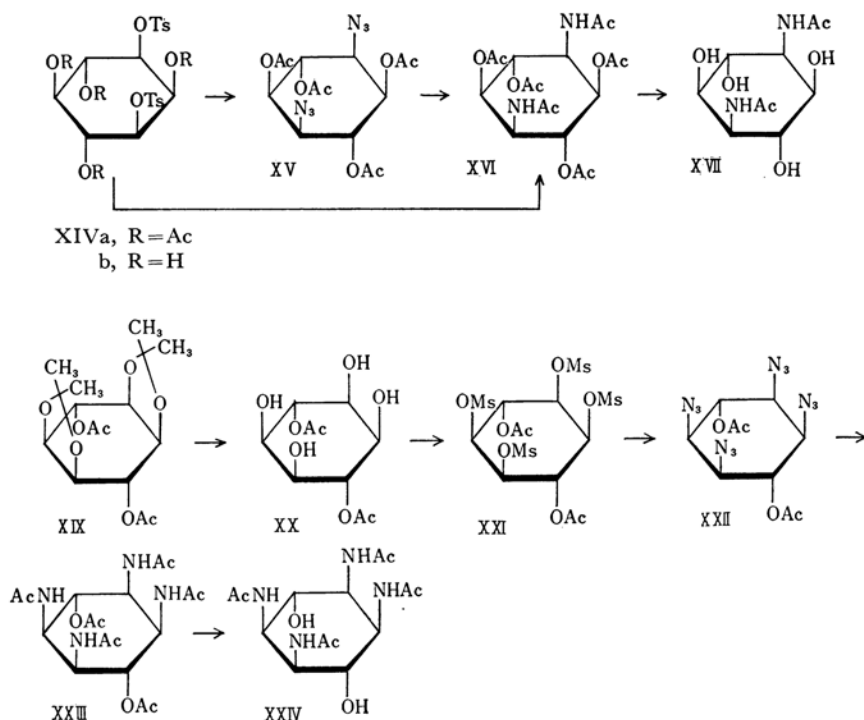

The doublet at τ 4.70 (4H) ($J=6.0$ cps) may be attributed to the ring protons on the carbon-bearing acetoxy groups. The spectrum of di-*N*-acetyl-*muco*-inosadiazine-3,6 (XI) in deuterium oxide shows one sharp signal, at τ 7.95, corresponding to two acetamido groups.

Considering the products obtained in this experiment, the following reaction mechanism can be proposed. The steric requirement for the formation of a cyclic acetoxonium ion is a trans disposition of an acetoxy group and a sulfonyloxy group.¹⁰⁾ However, it is not necessary for these groups to be axial. For example, penta-*O*-acetyl- β -D-glucopyranose forms the cyclic acetoxonium ion, but it is unlikely that a ring inversion to the all-axial alternative chair form would occur first.¹⁶⁾ If such an inversion were valid in general, in the present case there might be a chance to form two acetoxonium ions in a molecule at the same moment. However, it is more advantageous to have the cyclic ion, when they are in axial positions. Therefore, it seems more reliable to say that the displacement of the sulfonyloxy groups by azide ions proceeds step by step, one by one, in compound VIII.

The reaction of VIII with sodium azide might give the first intermediate cyclic acetoxonium ion, because there are three axial groups, on C-2, C-3 and C-4. Then the cyclic ion is attacked by a nucleophilic azide ion, predominantly in the manner

of a trans-diaxial opening, to give 3-azido-3-deoxy-6-*O*-methanesulfonyl-*muco*-inositol tetraacetate. Then the ring inversion takes place, giving an alternative chair form in which another methanesulfonyloxy group and the other acetoxy groups are now in the axial positions.

Therefore, the second cyclic ion can be formed; it is opened by an azide ion in the same manner as has been described above to give 3,6-diazido-3,6-dideoxy-*muco*-inositol derivative as the main product. Also, 4,6-diazido-4,6-dideoxy-*myo*-inositol derivative has been obtained as a minor product, and the presence of unidentified aminocyclitols is detected by paper chromatography. Therefore, it might be concluded that the main product is obtained through the trans-diaxial opening of an intermediary acetoxonium ion by an azide ion, while the minor compounds are obtained through its trans-diequatorial opening.

***muco*-Inosadiazine-1,4.** Recently Angyal *et al.*⁷⁾ reported the preparation of 2,4,5,6-tetra-*O*-acetyl-1,3-di-*O*-*p*-toluenesulfonyl-*myo*-inositol (XIV), which, concerning the known replaceability of sulfonyloxy groups by azide ions, seems to be an attractive starting material for the preparation of hitherto unknown inosadiazines.

When carrying out the azide replacement reaction with XIV (40 hr in 90% aqueous 2-methoxyethanol at 120°C), both of the *p*-toluenesulfonyloxy groups are eliminated to afford 1,4-diazido-1,4-dideoxy-*muco*-inositol (XV), in the form of its tetraacetate, in 48% yield. This was then

16) E. L. Eliel, N. L. Allinger, S. J. Angyal and G. A. Morrison, "Conformational Analysis," Interscience, New York (1965), pp. 426-428.

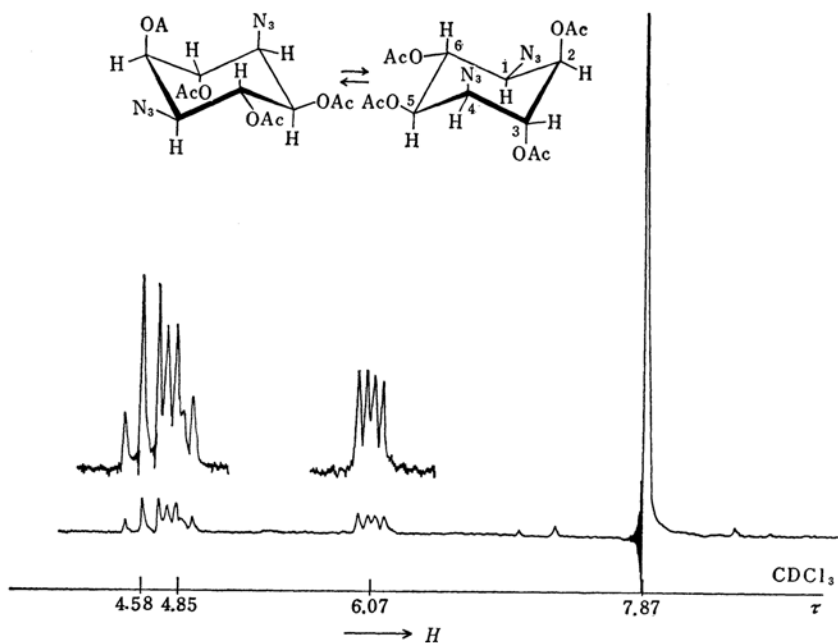

Fig. 3

hydrogenated to give, after a subsequent acetylation, hexaacetyl-*muco*-inosadiazide-1, 4 (XVI).

The same product, XVI, was obtained in 80% yield upon the treatment of 1, 3-di-*O*-*p*-toluenesulfonyl-*myo*-inositol (XVIII) with methanolic ammonia at 110–130°C for 30 hr and upon a subsequent acetylation.

The de-*O*-sulfonation of XIV by sodium azide in 90% aqueous 2-methoxyethanol can proceed through different stereochemical mechanisms. Though in relatively nonpolar solvents the anchimeric assistance of the neighboring *trans*-acetoxy groups in the displacement of the sulfonyloxy moieties can readily take place,¹⁷ a direct S_N2-elimination cannot be excluded. Subsequently, by the combination of these mechanisms, five isomers are theoretically possible: *rac*-1, 4, *muco*-1, 4-inosadiazides, and the already known compounds of *muco*-1, 5,¹⁷ *myo*-1, 3,^{17,18} and *rac*-1, 3¹⁹ configurations.

The inosadiazide hexaacetate obtained (mp 248–250°C) was not identical with any of the known isomers. The remaining inosadiazides (*rac*-1, 4 and *muco*-1, 4), could easily and unequivocally be differentiated on the basis of PMR-spectral data.

The PMR spectrum of the diazido-derivative, XV, exhibits one signal, at τ 7.87, corresponding to

twelve protons, and thus, to four stereochemically-equivalent acetoxy groups (Fig. 3). The ring protons at C-1 and C-4 (H-1 and H-4) appear as a quartet at τ 6.07, with the coupling constants of 6.0 and 3.5 cps. By assuming the rapid inversion of two alternative identical conformations, these coupling constants in the quartet can be easily explained: H-1 is coupled to H-2 with the coupling constant of 6.0 cps, which is a time-average value of J_{aa} and J_{ee} , and is also coupled with H-4 with the coupling constant of 3.4 cps, which is a time-average value of J_{ae} and J_{ea} .

The PMR spectra of XVI and XVII, listed in Table 1, also support the configuration of *muco*-inosadiazide-1, 4.

On the basis of these results the stereochemical course of the reaction can be assumed to be as follows: the displacement of one of the two sulfonyloxy groups gives an intermediate acetoxonium ion, with the participation of the neighboring *trans*-acetoxy group, which is then cleaved by an azide ion in a *trans*-diaxial manner. The other sulfonyloxy group is replaced in much the same manner, though in this case, *muco*-inosadiazide-1, 4 is obtained exclusively. This selective reaction can be understood by assuming an effect of a *trans* axial group neighboring to an intermediate acetoxonium ion on an attacking nucleophile.

***muco*-Inosatetraamine-1, 2, 4, 5.** An analogous reaction was conducted with 3, 6-di-*O*-acetyl-1, 2, 4, 5-tetra-*O*-methanesulfonyl-*muco*-inositol (XXI). When XXI was treated with sodium azide in boiling aqueous 2-methoxyethanol, the tetraazido derivative (XXII) was obtained. The

17) M. Nakajima, N. Kurihara, A. Hasegawa and T. Kurokawa, *Liebigs Ann. Chem.*, **689**, 243 (1965).

18) F. W. Lichtenthaler, H. Leinert and T. Suami, *Chem. Ber.*, in press.

19) M. Nakajima, A. Hasegawa and F. W. Lichtenthaler, *Liebigs Ann. Chem.*, **669**, 75 (1963).

hydrogenation of XXII in the presence of a catalyst, followed by acetylation, gave hexaacetyl-*muco*-inosatetraamine-1, 2, 4, 5 (XXIII). The structure of XXIII was also substantiated by its PMR spectrum.

The reaction mechanism described above might be proposed for this reaction also.

Experimental

The melting points were determined on a Mitamura Riken micro hot stage. The melting points marked with asterisks were measured in a liquid bath and are uncorrected. The infrared spectra were determined by means of pressed potassium bromide disks. The PMR spectra of the samples were determined at a frequency of 60 Mc with a Japan Electron Optics JNM-C-60 spectrometer in deuteriochloroform, deuterium oxide, or dimethylsulfoxide- d_6 , with tetramethylsilane, sodium trimethylsilylpropanesulfonate, or tetramethylsilane, respectively used as an internal standard.

1, 4, 5, 6-Tetra-*O*-acetyl-3-*O*-*p*-toluenesulfonyl-*myo*-inositol (I). This compound was prepared in 81% yield from 1, 4, 5, 6-tetra-*O*-acetyl-*myo*-inositol²⁰ by the method of Angyal et al.⁷

Hexaacetyl-*muco*-inositol (III). a) A mixture of 1, 4, 5, 6-tetra-*O*-acetyl-3-*O*-methanesulfonyl-*myo*-inositol (III)⁸ (1.0 g), anhydrous sodium acetate (1.0 g), and 90% aqueous 2-methoxyethanol (20 ml) was refluxed for 15 hr. The reaction mixture was then evaporated *in vacuo* to dryness. After acetylation, the residue was crystallized in ethanol. The crystals were collected and washed with alcohol to give hexaacetyl-*muco*-inositol (0.66 g) in 64% yield, which melted at 176–178°C. Recrystallization from ethanol gave colorless crystals (0.50 g), melting at 176.5–178°C, in a 49% yield. (Found: C, 50.03; H, 5.59%).

b) A mixture of I (15.0 g), anhydrous sodium acetate (15.0 g), and 90% aqueous 2-methoxyethanol (290 ml) was treated in a manner similar to that described above in a); it yielded a crude product of I (9.5 g), melting at 177–178°C, in 74% yield. Recrystallization from methanol gave colorless crystals (7.4 g), melting at 177–178°C, in 56% yield.

***muco*-Inositol (IV).** A mixture of III (8.0 g), ml of ethanol, and 120 ml of concentrated hydrochloric acid was refluxed for 1 hr, and then evaporated *in vacuo*. The residue was digested in ethanol to give crystals (3.3 g) melting at 284°C with decomposition in a 98% yield. (Lit.²¹ mp 280–300°C)

1, 2 : 4, 5-Di-*O*-isopropylidene-*muco*-inositol (V). This compound was prepared by the method of Angyal et al.¹¹

1, 2 : 4, 5-*O*-Diisopropylidene-3, 6-di-*O*-methanesulfonyl-*muco*-inositol (VI). To a solution of V (1.98 g) in dry pyridine (20 ml), methanesulfonyl chloride (1 ml) was added, drop by drop, under ice cooling with agitation. The reaction mixture was allowed to stand at room temperature overnight and then poured into a mixture of ice and water to give the crude product (3.01 g, 95.0% yield), melting at *233–234°C. An analytical sample was obtained by recrystallization from ethanol, and its melting point did not change.

Found: C, 40.28; H, 5.84; S, 15.18%. Calcd for $C_{14}H_{24}O_{10}S_2$: C, 40.39; H, 5.81; S, 15.40%.

3, 6-Di-*O*-methanesulfonyl-*muco*-inositol (VII). A 2.0 g portion of VI was hydrolyzed in 40 ml of 90% aqueous acetic acid under reflux for 2 hr. The mixture was then evaporated to give an oily residue, which was crystallized by triturating in ethanol. The crude product weighed 1.25 g (78% yield) and melted at 180–183°C (decompose). Recrystallization from 2-methoxyethanol gave colorless crystals melting at 190.5–193°C.

Found: C, 28.68; H, 4.87; S, 18.63%. Calcd for $C_8H_{16}O_{10}S_2$: C, 28.57; H, 4.79; S, 19.07%.

1, 2, 4, 5-Tetra-*O*-acetyl-3, 6-di-*O*-methanesulfonyl-*muco*-inositol (VIII). VII (1.02 g) was acetylated with a mixture of acetic anhydride (5 ml) and pyridine (5 ml) to give 1.49 g (97.5% yield) of the crude product, melting at 182–184°C. Recrystallization from ethanol gave colorless plates melting at 183–184.5°C.

Found: C, 38.40; H, 4.83; S, 12.73%. Calcd for $C_{16}H_{24}O_{14}S_2$: C, 38.10; H, 4.80; S, 12.72%.

1, 2, 4, 5-Tetra-*O*-acetyl-3, 6-diazido-3, 6-dideoxy-*muco*-inositol (IX) and 1, 2, 3, 5-Tetra-*O*-acetyl-4, 6-diazido-4, 6-dideoxy-*myo*-inositol (XIII). A mixture of VIII (2.0 g), sodium azide (2.0 g) and 90% aqueous 2-methoxyethanol (80 ml) was heated under reflux for 46 hr. Then the reaction mixture was filtered to remove an insoluble material, and the filtrate was evaporated under reduced pressure. The residue was repeatedly extracted with hot ethanol, and the extract was evaporated again. The residual oil was acetylated with a mixture of acetic anhydride and pyridine to give a crystalline product after the excess acetylating reagent had been removed by evaporation. A fractional recrystallization of the crude product from ethanol gave crystals of IX (1.20 g, 76.0% yield) melting at 168–171°C and colorless plates (0.057 g, 3.6% yield) melting at 143–148°C. IX was further recrystallized from ethanol to give needles melting at 171–172°C.

Found: C, 42.53; H, 4.63; N, 21.01%. Calcd for $C_{14}H_{16}N_6O_8$: C, 42.21; H, 4.55; N, 21.10%.

The latter crystals were recrystallized from ethanol to give crystals (47 mg), melting at 148–149.5°C, which were identified as XIII by a mixed-melting-point determination and by a study of their infrared spectrum.

When the same reaction was carried out using 90% aqueous dimethylformamide instead of 2-methoxyethanol as a solvent, only IX was obtained (in 46% yield), and no XIII could be isolated from the reaction products.

Hexaacetyl-*muco*-inosadiazine-3, 6 (X). IX (0.53 g) was hydrogenated in ethanol (120 ml) with a few drops of ethanolic ammonia over Adams platinum oxide (50 mg) under an initial hydrogen pressure of 50 psi for 3 hr. The reduction product was then acetylated to give 0.49 g (78% yield) of crystals melting at 138–140°C. Recrystallization from ethanol gave plates also melting at 138–140°C. An analytical sample was dried over phosphorus pentoxide at 90–100°C for 24 hr.

Found: C, 47.51; H, 6.37; N, 6.42%. Calcd for $C_{18}H_{26}N_2O_{10} \cdot \frac{3}{2}H_2O$: C, 47.28; H, 6.39; N, 6.13%.

Di-*N*-acetyl-*muco*-inosadiazine-3, 6 (XI). X (0.32 g) was added to methanol (30 ml) which had previously been saturated by ammonia, and the solution

20) S. J. Angyal, M. E. Tate and S. D. Gero, *J. Chem. Soc.*, 1961, 4116.

was allowed to stand overnight at room temperature. Then the solution was evaporated *in vacuo* to give an oily residue, which crystallized in methanol. The crystals (0.18 g) were collected by filtration (mp 282°C decompose). The product was recrystallized from aqueous ethanol to give colorless plates melting at 285–286°C.

Found: C, 46.00; H, 7.14; N, 10.56%. Calcd for $C_{10}H_{18}N_2O_6$: C, 45.79; H, 6.92; N, 10.68%.

muco-Inosadiazine-3, 6 Dihydrochloride (XII).

A 0.48 g portion of IX was hydrogenated as has been described above. The crude reduction product was hydrolyzed in 6*N* hydrochloric acid on a boiling water bath for 2.5 hr. The solution was then evaporated to give a crystalline residue, which was digested in ethanol to give 0.25 g of the crude product. Recrystallization from aqueous ethanol gave needles melting at *303°C (decompose), after sintering at 290°C.

Found: C, 28.96; H, 6.37; N, 10.94; Cl, 28.42%. Calcd for $C_6H_{14}N_2O_4 \cdot 2HCl$: C, 28.70; H, 6.42; N, 11.15; Cl, 28.24%.

Paper Chromatography. The dihydrochloride, XII, gave a single spot of R_f 0.16 in an ethyl acetate-pyridine-acetic acid-water (5 : 5 : 1 : 3) system in ascending development at 20–23°C with a ninhydrin spray. (R_f of D-glucosamine hydrochloride: 0.35).

After the crystalline products, IX and XIII, had been removed, the mother liquor was evaporated. The residual oil was hydrogenated as has been described in the preparation of X. The crude reduction product was hydrolyzed in 6*N* hydrochloric acid and then evaporated. The crude product was detected in the same system as has been described above. The R_f values were as follows: 0.10, 0.18, and 0.22 (R_f of D-glucosamine hydrochloride: 0.32).

2, 4, 5, 6-Tetra-O-acetyl-1, 3-di-O-p-toluenesulfonyl-myo-inositol (XIVa). This compound was prepared by the method of Angyal *et al.*⁷⁾

1, 3-Di-O-p-toluenesulfonyl-myo-inositol (XIVb). A 5.0 g portion of XIVa was de-O-acetylated by methanolic ammonia (120 ml) for 2 days to give 2.5 g (71% yield) of needles, melting at 230.5–232°C, after recrystallization from ethanol. An analytical sample melting at 232–233°C was obtained by further recrystallizations from ethanol. Found: C, 48.80; H, 4.98; S, 13.07%. Calcd for $C_{20}H_{24}O_{10}S_2$: C, 49.18 H, 4.95; S, 13.13%.

2, 3, 5, 6-Tetra-O-acetyl-1, 4-diazido-1, 4-dideoxy-muco-inositol (XV). A mixture of XIVa (3.0 g), sodium azide (3.0 g), and 90% aqueous 2-methoxyethanol (90 ml) was heated to reflux for 40 hr. The reaction mixture was then treated analogously as described in the preparation of IX to give 1.22 g of the crude product. The product was recrystallized from ethanol to give 0.87 g (48% yield) of colorless plates melting at 110–111.5°C.

Found: C, 42.46; H, 4.77; N, 21.13%. Calcd for $C_{14}H_{18}N_6O_8$: C, 42.21; H, 4.55; N, 21.10%.

The existence of no other isomers was observed by thin layer chromatography.

Hexaacetyl-muco-inosadiazine-1, 4 (XVI). a) A 271 mg portion of XV was hydrogenated as has been described above to yield 232 mg (80% yield) of crystals, melting at 248–249.5°C, after sintering at 170°C. Recrystallization from ethanol gave colorless plates (156 mg) melting at 248–250°C.

Found: C, 50.28; H, 6.08; N, 6.43%. Calcd for $C_{18}H_{26}N_2O_{16}$: C, 50.23; H, 6.09; N, 6.51%.

b) A mixture of XIVb (1.70 g) and methanol (120 ml) saturated with ammonia was heated at 110–130°C for 30 hr in an autoclave. The mixture was then evaporated *in vacuo* and acetylated to give 1.20 g (80% yield) of a crude product, melting at 249–251°C, after sintering at 170°C. Recrystallization from ethanol gave 0.94 g of plates melting at 248–250°C; these plates were identified as the same as the analytical sample described above by a mixed melting point determination and by a study of the infrared spectra.

Paper Chromatography. The hexaacetate was hydrolyzed in 6*N* hydrochloric acid. The dihydrochloride gave a single spot (R_f 0.20) in the system described above.

Di-N-acetyl-muco-inosadiazine-1, 4 (XVII). The selective de-O-acetylation of XVI (0.44 g) in methanolic ammonia gave 0.22 g (79% yield) of crystals, melting at *209–210°C (decompose), after the recrystallization of a crude product from ethanol. An analytical sample was dried over phosphorus pentoxide at 90°C for 20 hr.

Found: C, 44.18; H, 6.89; N, 10.32%. Calcd for $C_{10}H_{18}N_2O_6 \cdot \frac{1}{2}H_2O$: C, 44.26; H, 7.06; N, 10.33%.

3, 6-Di-O-acetyl-1, 2, 4, 5-di-O-isopropylidene-muco-inositol (XIX). V (0.65 g) was acetylated in the way described above to give 0.76 g (89% yield) of a crude product melting at 202–204.5°C. Recrystallization from ethanol gave crystals melting at *202.5°–203.5°C.

Found: C, 55.99; H, 6.95%. Calcd for $C_{16}H_{24}O_8$: C, 55.80; H, 7.03%.

3, 6-Di-O-acetyl-muco-inositol (XX). XIX (0.55 g) was hydrolyzed in 80% aqueous acetic acid by heating the mixture on a steam bath for 1 hr. The product was then recrystallized from ethanol to give 0.33 g (78% yield) of needles melting at 201–201.5°C.

Found: C, 45.75; H, 6.16%. Calcd for $C_{10}H_{16}O_5$: C, 45.45; H, 6.10%.

3, 6-Di-O-acetyl-1, 2, 4, 5-tetra-O-methanesulfonyl-muco-inositol (XXI). When 0.32 g of XX was treated with 1 ml of methanesulfonyl chloride in dry pyridine in a manner analogous to that described for the preparation of VI, 0.70 g (99% yield) of a crude product melting at 215–218°C was obtained. Recrystallization from 2-methoxyethanol gave plates melting at *212–213°C.

Found: C, 29.35; H, 3.93; S, 21.82%. Calcd for $C_{14}H_{24}O_{16}S_4$: C, 29.16; H, 4.20; S, 22.24%.

Hexaacetyl-muco-inosatetraamine-1, 2, 4, 5 (XXIII). A mixture of XXI (1.40 g), sodium azide (1.40 g) and 90% aqueous 2-methoxyethanol (60 ml) was heated to reflux for 40 hr. Then the mixture was treated much as has been described in the preparation of IX to give crystals which showed a characteristic infrared absorption peak of the azido group at 2050 cm^{-1} . The crystals were acetylated with a mixture of acetic anhydride and pyridine, and then hydrogenated in ethanol (20 ml) over Adams platinum oxide (40 mg) in hydrogen stream of 50 psi for 5 hr. The reduction product was acetylated, and the acetylated product was crystallized from a mixture of ethanol and ether to give 0.28 g (29% yield) of a product melting at 265–268°C, after melting at 165–172°C and resolidifying at 180°C. Recrystallization from ethanol gave 0.22 g

of colorless sticks melting at 268—272°C after showing the same melting and resolidifying behavior. An analytical sample was obtained by further recrystallization of the product and dried over phosphorus pentoxide *in vacuo* at 90—100°C for 24 hr.

Found: C, 45.05; H, 7.11; N, 11.70%. Calcd for $C_{13}H_{28}N_4O_8 \cdot 3H_2O$: C, 44.82; H, 7.10; N, 11.61%.

Tetra-*N*-acetyl-*muco*-inosatetraamine-1, 2, 4, 5 (XXIV). A 415 mg portion of XXIII was treated with methanolic ammonia to give 295 mg of crystals. Recrystallization from aqueous ethanol gave long needles (130 mg) melting at *310—312°C (decomp.). The analytical sample was dried over phosphorus pentoxide *in vacuo* at 90—100°C for 10 hr.

Found: C, 46.64; H, 7.14; N, 15.60%. Calcd for $C_{14}H_{24}N_4O_8 \cdot H_2O$: C, 46.40; H, 7.23; N, 15.46%.

The authors are grateful to Professor Sumio Umezawa for his kind advice, and to Mr. Saburo Nakada for his elementary analyses. The authors are also indebted to the Tanabe Pharmaceutical Co., Ltd., and to the Japan Electron Optics Co., Ltd., for their measurements of the PMR spectra. This research has been financially supported in part by a grant of the Japanese Ministry of Education and by the Deutsche Forschungsgemeinschaft, to which the authors' thanks are due.
